

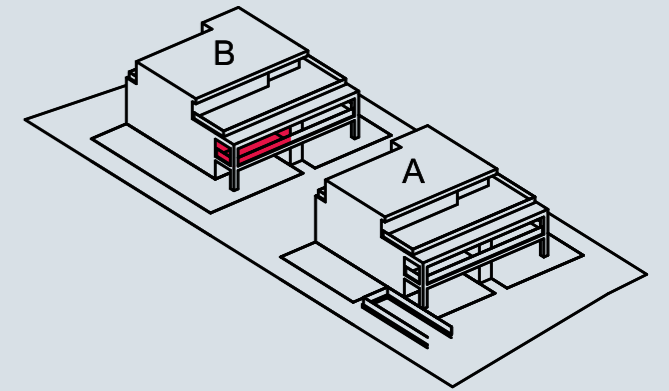

Wohnung B-04

Haus B | 1. Obergeschoss



4.5 Zimmer Etagenwohnung

Nettonutzfläche 118.60 m²

Balkon gedeckt 25.00 m²

Keller 9.80 m²

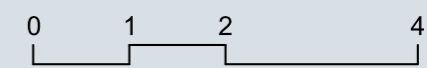

Massstab 1:100 | Print A3



Nord

